



TemperPack

2019/20



°ClimaCell

TECHNICAL PACKET

2019

This document outlines the ready-engineered ClimaCell insulated shipping solutions offered by TemperPack, a sustainable packaging company.



CLIMACELL TECHNICAL PACKET

2019/20



CONTENTS

04

ABOUT TEMPERPACK

- 05 Meet the Team
- 08 Proving Ground

10

CLIMACELL

- 12 ClimaCell Features

14

READY-ENGINEERED SOLUTIONS

- 16 2-8°C Summer Performance
- 20 2-8°C Winter Performance

22

CUSTOM SOLUTIONS

23

FULL-SERVICE PARTNER

- 24 Messaging Performance
- 25 Messaging Sustainability
- 26 Working with TemperPack

ABOUT TEMPERPACK

Seeking to solve the world's packaging problems through sustainable design.

TemperPack was borne out of a desire to reduce the amount of unsustainable packaging that correlated with the growing world of e-commerce delivery.

Our founders saw an opportunity in perishable delivery where innovation had stagnated and companies were still using insulation products that had been developed over 60 years ago.

Today, TemperPack operates three facilities in Virginia and Nevada and is rapidly expanding its reach in the perishable and cold chain shipping market, all with the goal of reducing the amount of packaging that ends up in landfills.



ZERO COMPROMISE

At TemperPack, we believe that you shouldn't have to compromise quality or performance to also be sustainable. Our thermal packaging solutions offer 1:1 R-Value comparison to EPS of similar thickness.



In the last year, TemperPack has ended the creation of 25 million pounds of CO₂E from being produced.



We've helped protect over 20 million of our clients' shipments, making us the largest EPS alternative supplier in the country.



In 2018, we helped our clients divert 10 million pounds of plastic foam from entering the Earth's landfills.

We're in a race to become the market leader in sustainable thermal packaging and insulation that doesn't harm the planet. It's a multi-billion dollar category and it's dominated by Styrofoam.

- BRIAN POWERS,
CO-FOUNDER & CO-CEO
OF TEMPERPACK

At TemperPack, we've found a niche in developing thermal packaging solutions for clients shipping perishable goods. We focus on understanding the logistical headaches and consumer pain points of delivering and receiving perishable goods.

We combine our expertise in Packaging Design, Material Science, and Custom Manufacturing to build products that perform as well as or better than conventional shipping insulation but are more environmentally friendly.



BEST-IN-CLASS ENGINEERING

We have designed custom profiles, pack-outs, conceptual prototypes, and performed ISTA thermal qualification for companies like Express Scripts and HelloFresh.



LEADERS IN SUSTAINABILITY

TemperPack is the only manufacturer that is endorsed by Closed Loop Partners, Republic Services, and the Sustainable Packaging Coalition.



FUTURE-FOCUSED BUSINESS

We've lowered our cost structure 75% over 4 years and expect to be able to undercut commoditized EPS pricing within 3 years.

MEET THE TEAM



JAMES MCGOFF
CO-FOUNDER & CO-CEO

James graduated from McGill University with a degree in Materials Engineering. He spent time at Boeing Aerospace & Defense before founding TemperPack.



BRIAN POWERS
CO-FOUNDER & CO-CEO

Brian worked in investment banking at Moelis & Company before founding TemperPack. He holds a degree in finance from the Wharton School of Business.



CHARLES VINCENT
CO-FOUNDER & CTO

Charles graduated from McGill University with a degree in Materials Engineering.

We've built a team of innovators from many of the top companies in the country, all with the goal of designing and manufacturing a more sustainable alternative to EPS foam.



LOU MARMO
CHIEF OPERATING OFFICER

Lou joined TemperPack in 2019 after advising the co-founders for two years. He was previously the CFO of Liqui-Box and has 25 years of manufacturing industry experience.



BOB BECKLER
CHAIRMAN

Bob has over 30 years of experience working in the packaging industry. He previously served as President of Packaging at WestRock and joined TemperPack in 2017.

EVERY GREAT BUSINESS STARTS WITH AN IDEA

Our healthcare system relies on petroleum-based plastics—especially EPS foam. Patients don't think this is sustainable, and neither do we.

TemperPack was started by three young entrepreneurs in a garage to make a difference in the way we package things. Our company is deeply rooted in research and development, and our people value sustainable design that doesn't sacrifice quality and performance.

We're always looking for clients who share these values.

PROVING GROUND

Proving Ground is TemperPack's in-house thermal design and testing lab. It is one of the largest packaging labs in the United States, and one of the only ISTA-certified thermal transport labs in all of North America.

At Proving Ground, we have designed and tested over 500 thermal packaging systems for a wide variety of applications. Our world-class packaging engineers have the ability to rapidly design around almost any payload size, temperature range, or transit duration.



01

RAPID PROTOTYPING

Are you looking for samples to present to a manager for a meeting next week? At Proving Ground, TemperPack can produce and ship samples in days, not weeks.

02

READY-ENGINEERED SOLUTIONS

With ready-engineered solutions for 2-8C, CRT, and frozen applications, we're ready when you need a solution quickly.

03

QUALIFIED PERFORMANCE

TemperPack's systems come with the documentation you need to stay compliant with URAC, manufacturer requirements, regulating bodies, and the demands of your patients.

04

DESIGN & MESSAGING

Re-shipping due to perceived temperature excursions? The look and feel of packaging can determine a patient's confidence in a medication. We ensure that packaging communicates confidence.

ISTA® LABORATORY CERTIFICATION

We've demonstrated a strong commitment to packaging excellence by making Proving Ground an ISTA Certified Thermal Transport Lab. Specifically, our team is certified by the highest authorities in the field to design and qualify thermal packaging solutions per the ISTA Standard 20 protocol.

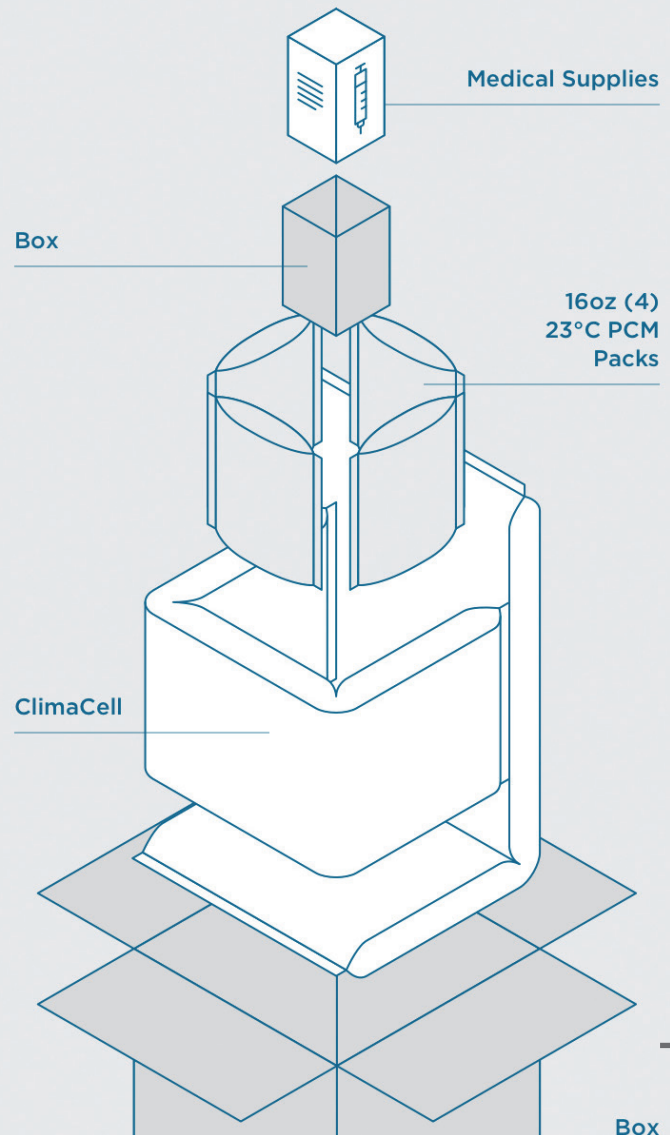

°ClimaCell



CLIMACELL IS A PLANT-BASED INSULATOR INVENTED BY TEMPERPACK. IT IS THE ONLY INSULATOR IN THE WORLD TO BE CERTIFIED “WIDELY RECYCLABLE” UNDER THE SUSTAINABLE PACKAGING COALITION’S HOW2RECYCLE® PROGRAM.

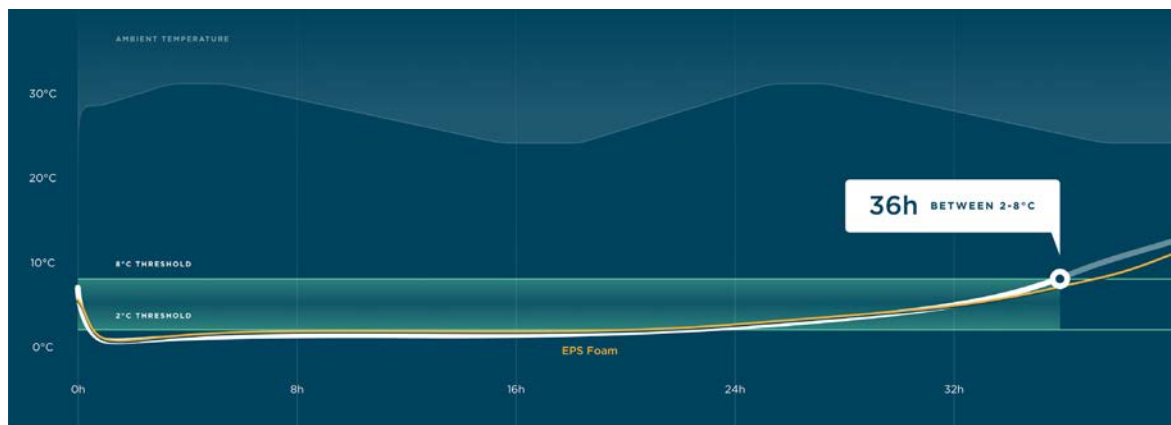

HIGH THERMAL PERFORMANCE

Want to move away from EPS foam without changing your pack-out? You can keep your current coolant configuration in a ClimaCell cooler, which performs just like EPS foam.



LOW COST STRUCTURE

Sustainability is great, but at the end of the day, we understand that budget is always a factor. ClimaCell systems are on par with EPS in cost.



PACKS AND SHIPS FLAT

ClimaCell packs flat and is easy to assemble, which means lower inbound and storage costs. Pre-kitted systems are available upon request.

CLIMACELL FEATURES

ClimaCell, is made from renewable plant-based components. With excellent thermal performance and a competitive cost structure, it is the ideal replacement for unsustainable insulators, like Styrofoam®. ClimaCell represents our understanding of the insulation market and seeks to improve the category by pushing it toward a more sustainable future.



CURBSIDE RECYCLABLE

Many packaging products claim curbside recyclability, but ClimaCell is the real deal. It's compliant with re-pulping standards developed by the Fibre Box Association, it's certified under How2Recycle®, and it has been endorsed by Closed Loop Partners.



CERTIFIED THERMAL PERFORMANCE

You don't have to take our word for it. With live distribution studies, ISTA-compliant chamber tests, and third-party K-Value evaluations, ClimaCell has been proven to perform on par with EPS foam.



BIO-BASED MATERIAL

While most insulators on the market are derived from petroleum, ClimaCell is composed of rapidly renewable, bio-based materials.



WIDELY CUSTOMIZABLE

ClimaCell can accommodate any payload size, can be customized to hold frozen temperatures, 2-8C, or controlled-room-temperatures, and can last for 12-72+ hours.



COMPETITIVELY PRICED

ClimaCell systems are cost-competitive with conventional thermal packaging, and while EPS gets more expensive every year, we're working to make our products even more affordable.

“We’ve been looking for an alternative to EPS foam for 10 years, but we haven’t been able to find anything cost-competitive that also performs. We are thrilled to have finally found a solution that works with TemperPack.”

- CORPORATE
SUSTAINABLE EXECUTIVE,
FORTUNE 500 LIFE
SCIENCES COMPANY





Off-the-Shelf Solutions

Don't have time to validate a new system? We get it. Talk to our sales team about our ready-engineered solutions for 2-8°C, 15-25°C, and frozen applications.

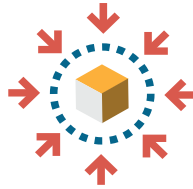

Moisture Resistant

Unlike other EPS foam alternatives, ClimaCell is built to hold up to coolant condensation while in transit.



93%
fewer
emissions

Looking to show reduced CO2e emissions on this years Corporate Responsibility Report? ClimaCell requires far less energy to manufacture than EPS foam.



Tooling-Free Manufacturing Process

Need to bring on a new cooler size? Don't worry- we can customize ClimaCell on the fly with no new tooling, which means there are no upfront costs to customization.



Ships & Packs Flat

Tired of paying to ship air every time you purchase molded foam coolers? ClimaCell ships and stores flat, meaning lower inbound freight and storage costs.

CLIMACELL FEATURES



Supply Continuity

Want a sustainable solution but can't find a national provider? We make millions of units a month across the US, and we stock ClimaCell with distributors throughout North America and Europe.



URAC Compliance

Need a validated packaging system for URAC accreditation? No problem. Our systems come with all of the paperwork you need to stay compliant.



Class 3 Packaging

Styrofoam® is a class 1 material, meaning it can go up in flames pretty quickly. For this reason, there are restrictions on how it is stored, and requirements for expensive fire-mitigation systems. With ClimaCell, you can say goodbye to these headaches.



Custom Branding



Lightweight



**READY-ENGINEERED
SOLUTIONS**

TemperPack has the fastest growing catalog of ready-engineered thermal shipping systems on the market, each powered by our highly insulating, curbside recyclable ClimaCell insulator. Don't see what you need here? **Contact our sales team to see what new systems are coming out this month.**

	PAYLOAD CAPACITY	TEMP. RANGE	SHIPPING DURATION	INNER DIMENSIONS	OUTER DIMENSIONS	REFRIGERANTS
CC10CUBE	Approx. 1.81L (Max)	2-8°C	31.5 HRS	7" x 7" x 7"	10" x 10" x 10"	3 x 16 oz Frozen Gels (2T & 1B) / PL: 125ml (-7%)
CC12CUBE	Approx. 3.65L (Max)	2-8°C	41.8 HRS	9" x 9" x 9"	12" x 12" x 12"	3 x 24 oz Frozen Gels (2T & 1B) / PL: 45ml (-1.25%)
CC14CUBE	Approx. 11.9L (Max)	2-8°C	30.4 HRS	11" x 11" x 11"	14" x 14" x 14"	4 x 32 oz Frozen Gels (2T & 2B) / PL: 500ml (-4.25%)
CC16CUBE	Approx. 27.70L (Max)	2-8°C	31.6 HRS	13" x 13" x 13"	16" x 16" x 16"	4 x 24 oz Frozen Gels (2T & 2B) / PL: 45ml (-0.16%)
CC11X9X10	Approx. 0.79L (Max)	2-8°C	38.8 HRS	8" x 6" x 7"	11" x 9" x 10"	3 x 24 oz Frozen Gels (2T & 1B) / PL: 45 ML (-5.7%)
CC11X9X12	Approx. 1.57L (Max)	2-8°C	40.3 (7.40°C) HRS	8" x 6" x 9"	11" x 9" x 12"	3 x 24 oz Frozen Gels (2T & 1B) / PL: 125ml (-8%)

Note: Any of the above ready engineered solutions can be modified to meet the specifications needed for shipping frozen and controlled room temperature (CRT) shipments.



2-8°C SUMMER

Managing efficacy in the harshest of climates.

This line of shippers can maintain 2-8°C for 24-55+ hours in extreme summer conditions. With a wide range of sizes and duration options, our line of 2-8°C ClimaCell Coolers is ideal for shipping biologics, vaccines, and other products requiring strict temperature control.

1:1 R-VALUE

COMPARED TO EPS ON AN INCH-FOR-INCH BASIS

ClimaCell is designed to perform just as well as its plastic-based alternatives.

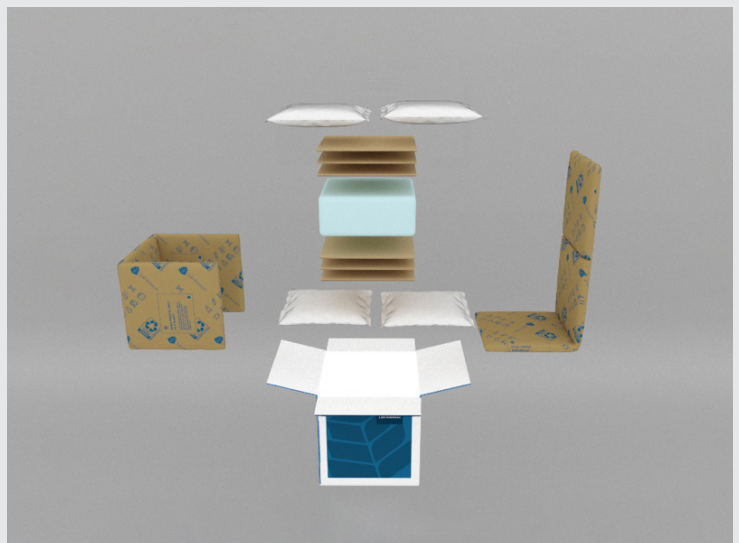
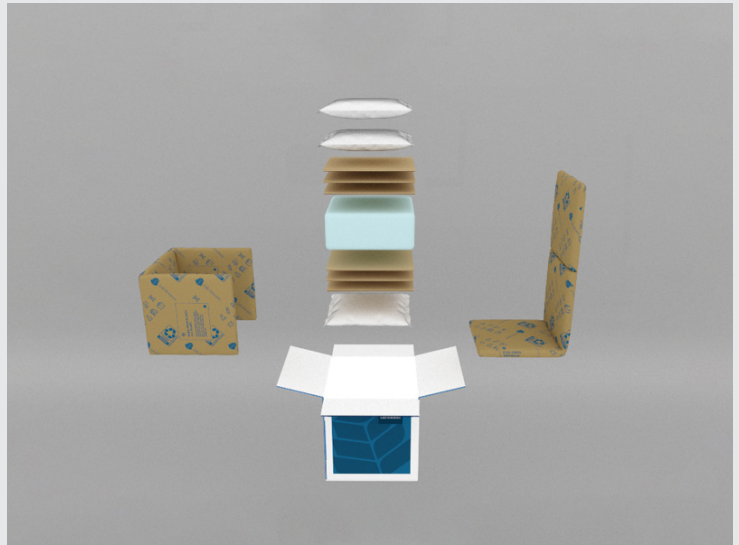

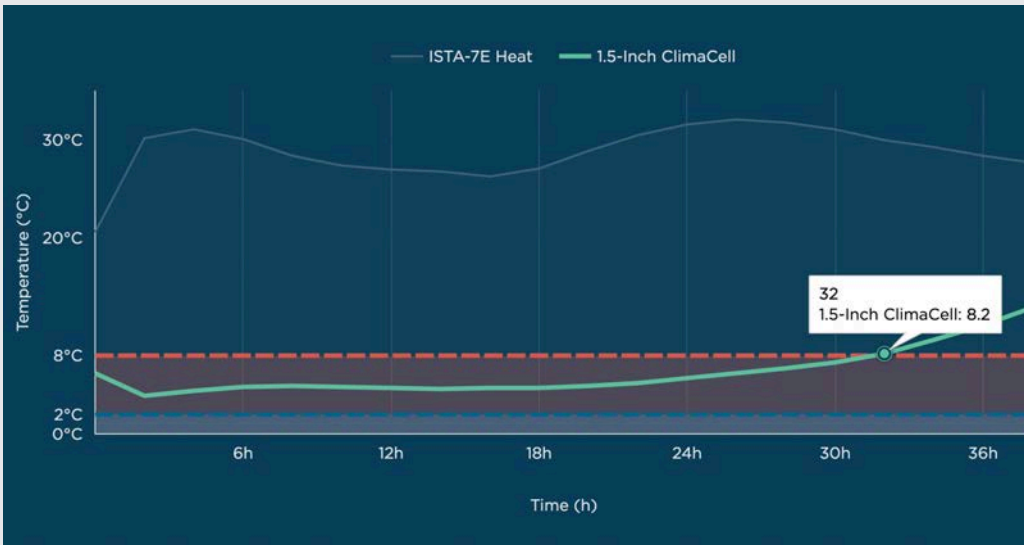

CC10CUBE

30+ hrs

The CC10CUBE ready-engineered shipping solution was packed using a 1.5-inch thick ClimaCell cooler, (3) 16oz frozen gel packs, (6) 32-ECT corrugated buffer pads, and kraft paper void fill. The pack-out is rated to 31.5 hours against an ISTA-7E Heat profile.

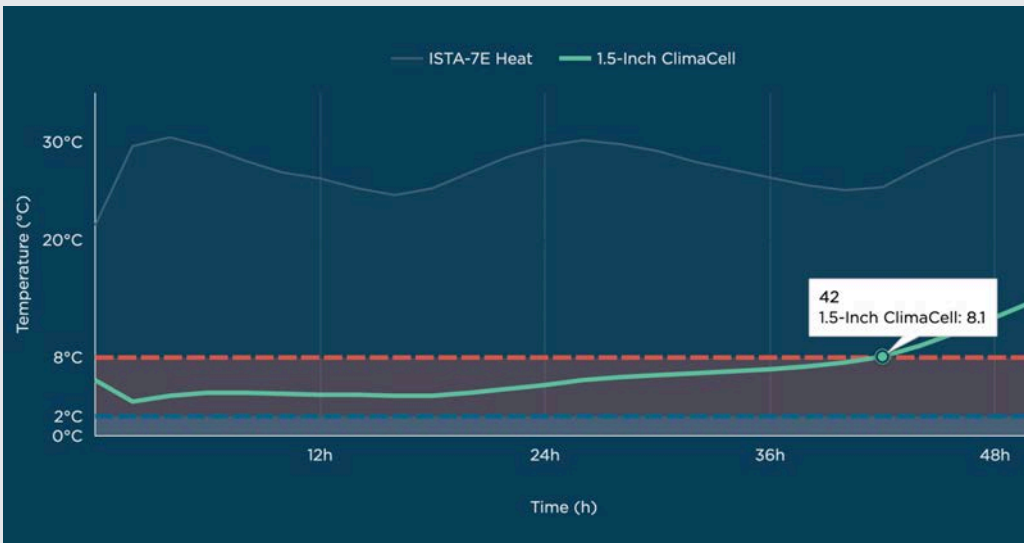

CC12CUBE

40+ hrs

The CC12CUBE ready-engineered shipping solution was packed using a 1.5-inch thick ClimaCell cooler, (3) 24oz frozen gel packs, (6) 32-ECT corrugated buffer pads, and kraft paper void fill. The pack-out is rated to 41.8 hours against an ISTA-7E Heat profile.

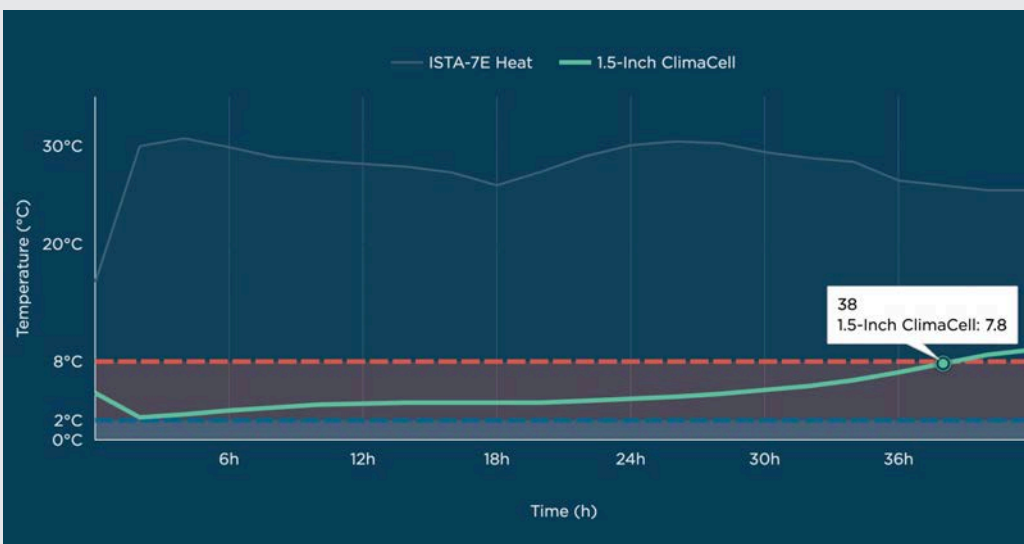

CC14CUBE

36+ hrs

The CC14CUBE ready-engineered shipping solution was packed using a 1.5-inch thick ClimaCell cooler, (4) 32oz frozen gel packs, (6) 32-ECT corrugated buffer pads, and kraft paper void fill. The pack-out is rated to 38.4 hours against an ISTA-7E Heat profile.



2-8°C SUMMER

(CONT.)

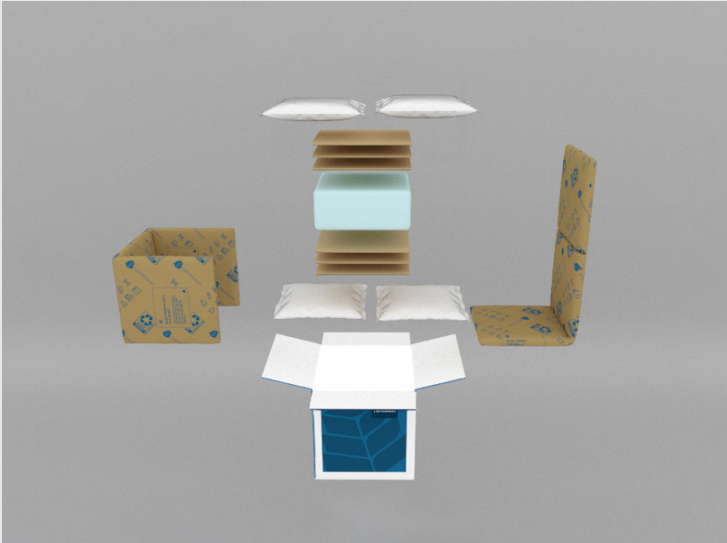

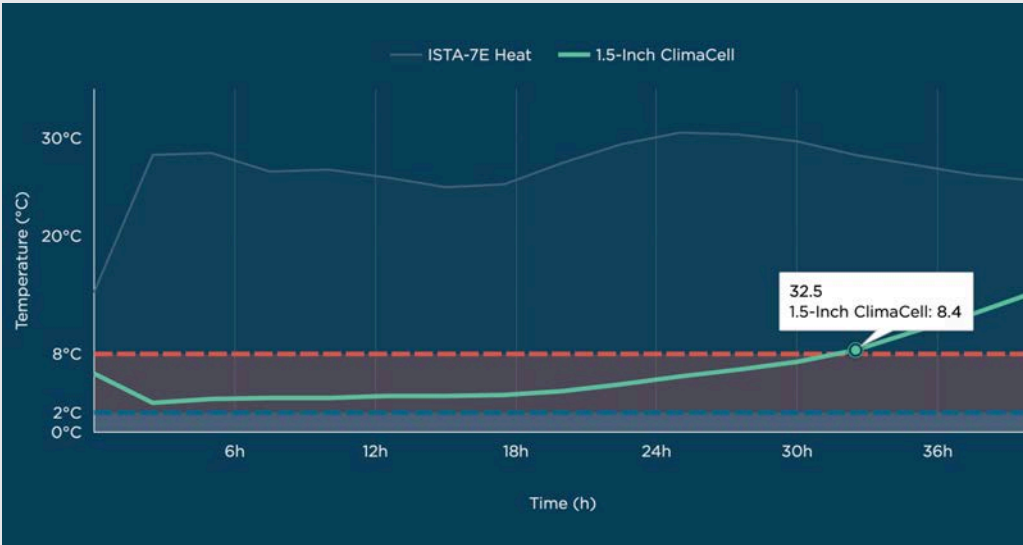

CC16CUBE

30+ hrs

The CC16CUBE ready-engineered shipping solution was packed using a 1.5-inch thick ClimaCell cooler, (4) 24oz frozen gel packs, (6) 32-ECT corrugated buffer pads, and kraft paper void fill. The pack-out is rated to 31.8 hours against an ISTA-7E Heat profile.

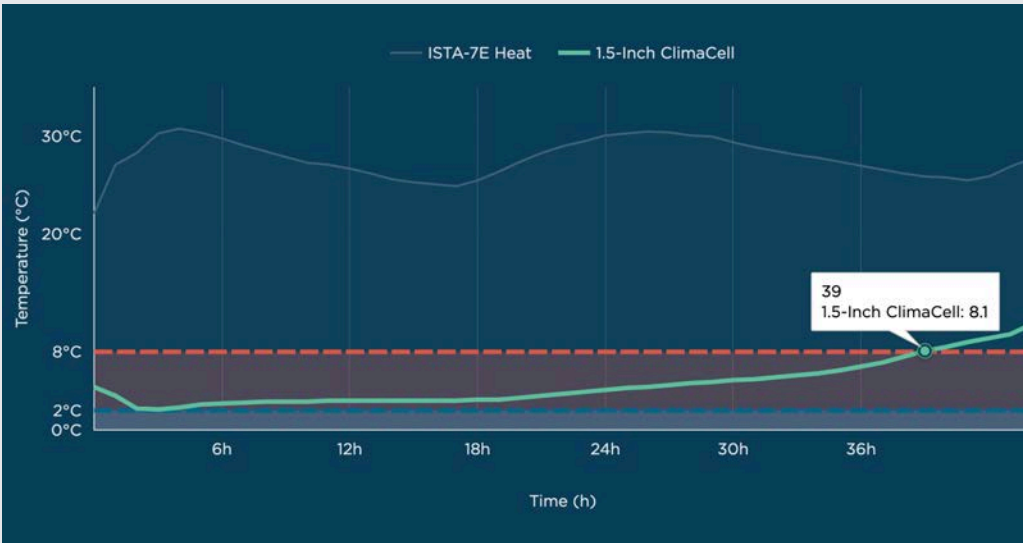

CC11X9X10

36+ hrs

The CC11X9X10 ready-engineered shipping solution was packed using a 1.5-inch thick ClimaCell cooler, (3) 24oz frozen gel packs, (6) 32-ECT corrugated buffer pads, and kraft paper void fill. The pack-out is rated to 38.9 hours against an ISTA-7E Heat profile.

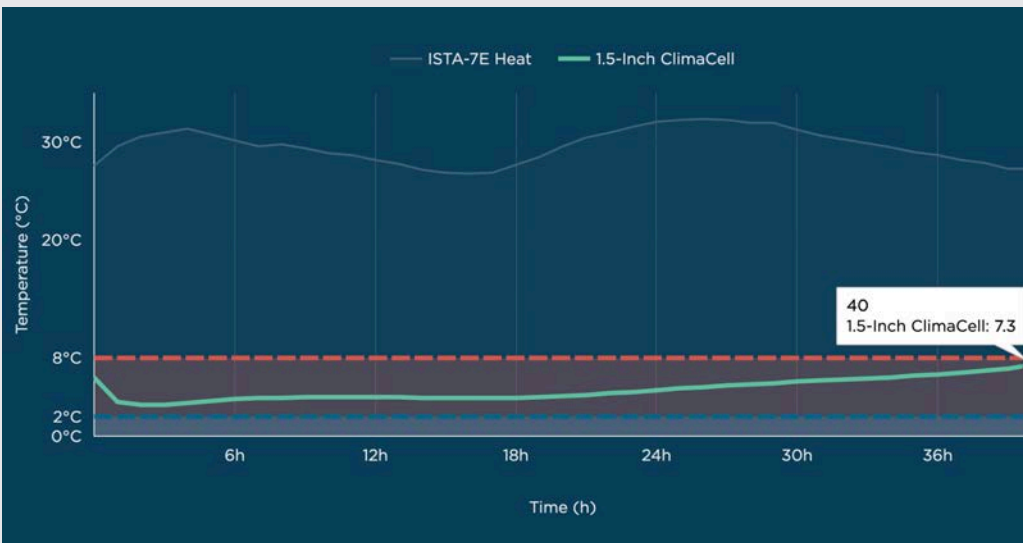

CC11X9X12

40+ hrs

The CC11X9X12 ready-engineered shipping solution was packed using a 1.5-inch thick ClimaCell cooler, (3) 24oz frozen gel packs, (6) 32-ECT corrugated buffer pads, and kraft paper void fill. The pack-out is rated to 40.3 hours against an ISTA-7E Heat profile.



2-8°C WINTER

Managing efficacy in the coldest of climates.

This line of shippers can maintain 2-8°C for 24-55+ hours in cold winter conditions. With a wide range of sizes and duration options, our line of 2-8°C ClimaCell Coolers is ideal for shipping biologics, vaccines, and other products requiring strict temperature control.

93%

REDUCED EMISSIONS

TO MANUFACTURE CLIMACELL OVER EPS

ClimaCell is significantly less energy intensive to produce than its EPS counterpart.

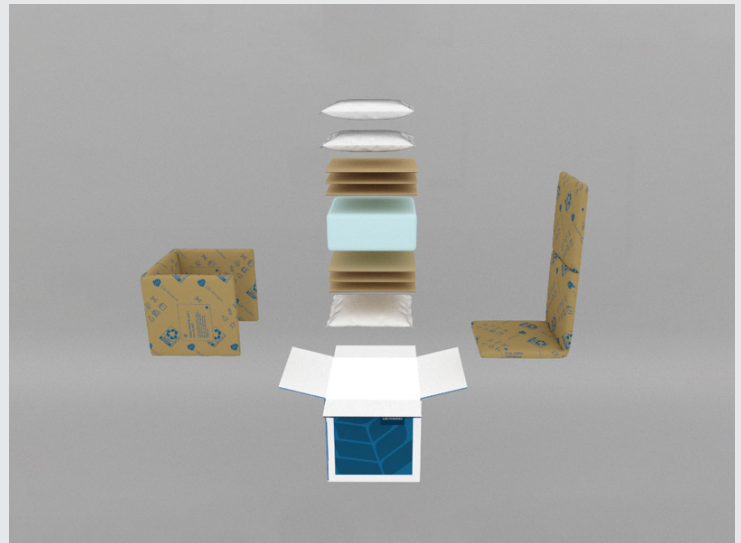

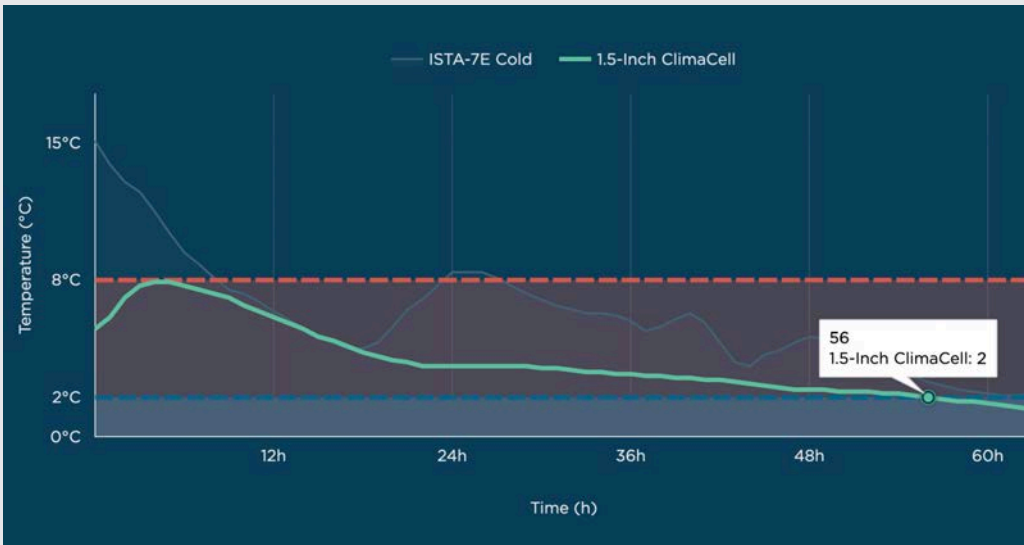

CC10CUBE

56+ hrs

The CC10CUBE ready-engineered shipping solution was packed using a 1.5-inch thick ClimaCell cooler, (1) 24oz frozen gel pack, (1) 24oz room temperature gel pack, (6) 32-ECT corrugated buffer pads, and kraft paper void fill. The pack-out is rated to 56.4 hours against an ISTA-7E Cold profile.

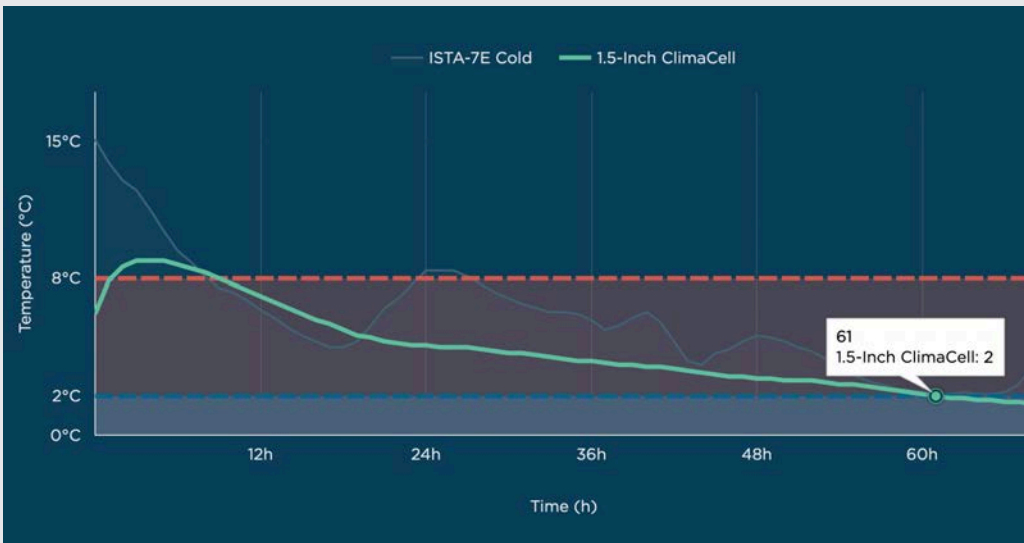

CC14CUBE

60+ hrs

The CC14CUBE ready-engineered shipping solution was packed using a 1.5-inch thick ClimaCell cooler, (1) 24oz frozen gel pack, (1) 24oz room temperature gel pack, (6) 32-ECT corrugated buffer pads, and kraft paper void fill. The pack-out is rated to 61.9 hours* against an ISTA-7E Cold profile.

*Payload reached a short excursion toward the beginning of the test but remained within the 10°C high excursion threshold.



CUSTOM SOLUTIONS

WE'LL HELP YOU SHIP ANYTHING, UNDER ANY PARAMETERS.

If you need a more unique shipper, we're happy to work with you to find a solution that meets your specific criteria. We have a team of thermal and packaging engineers ready to help you solve your shipping problems.

TemperPack's guiding design principles for new products:

01 HIGHLY INSULATING

It needs to function as good as or better than EPS foam solutions.

02 GLOBALLY SCALABLE

It should be made from commodity inputs available around the world.

03 COST EFFECTIVE

It should be as cheap or cheaper to produce at scale as EPS foam solutions.

04 CURBSIDE RECYCLABLE

It has to be curbside recyclable for easy end consumer disposal.

05 WIDELY CUSTOMIZABLE

It should be able to function across industries in a variety of uses.

ISTA® CERTIFIED THERMAL TESTING FOR ANY SEASON

Are you experiencing customer complaints regarding damaged packages or “warm on deliveries”? We’ll connect you with the engineers at our in-house lab, Proving Ground, to quickly address the issue.

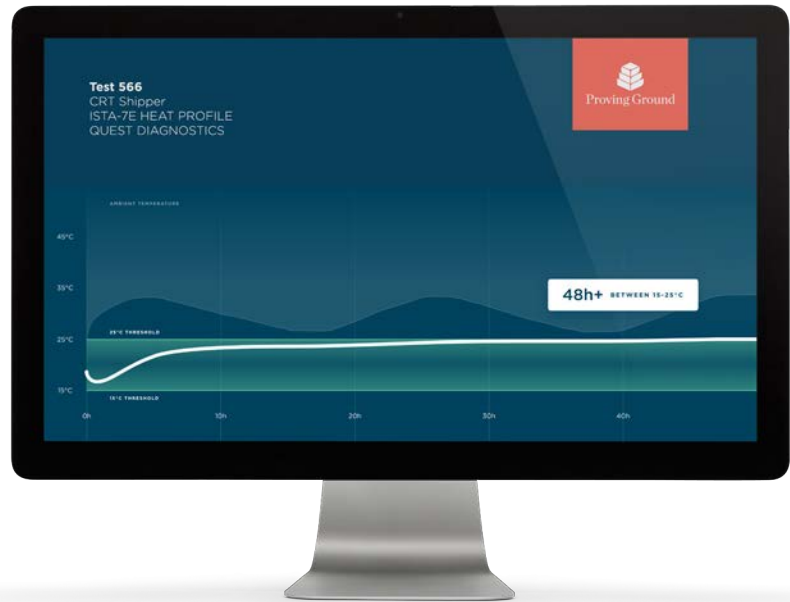

CUSTOM PACK-OUT DESIGN

Every custom designed product starts with a client’s specific criteria. How long will the shipment be in transit, where and when is it being shipped, what are the overall dimensions of the payload, and what are the stringent thresholds that we need to keep it within? Once we have that information, we begin to test how to pack that product to ensure efficacy while also using the fewest packaging materials necessary.

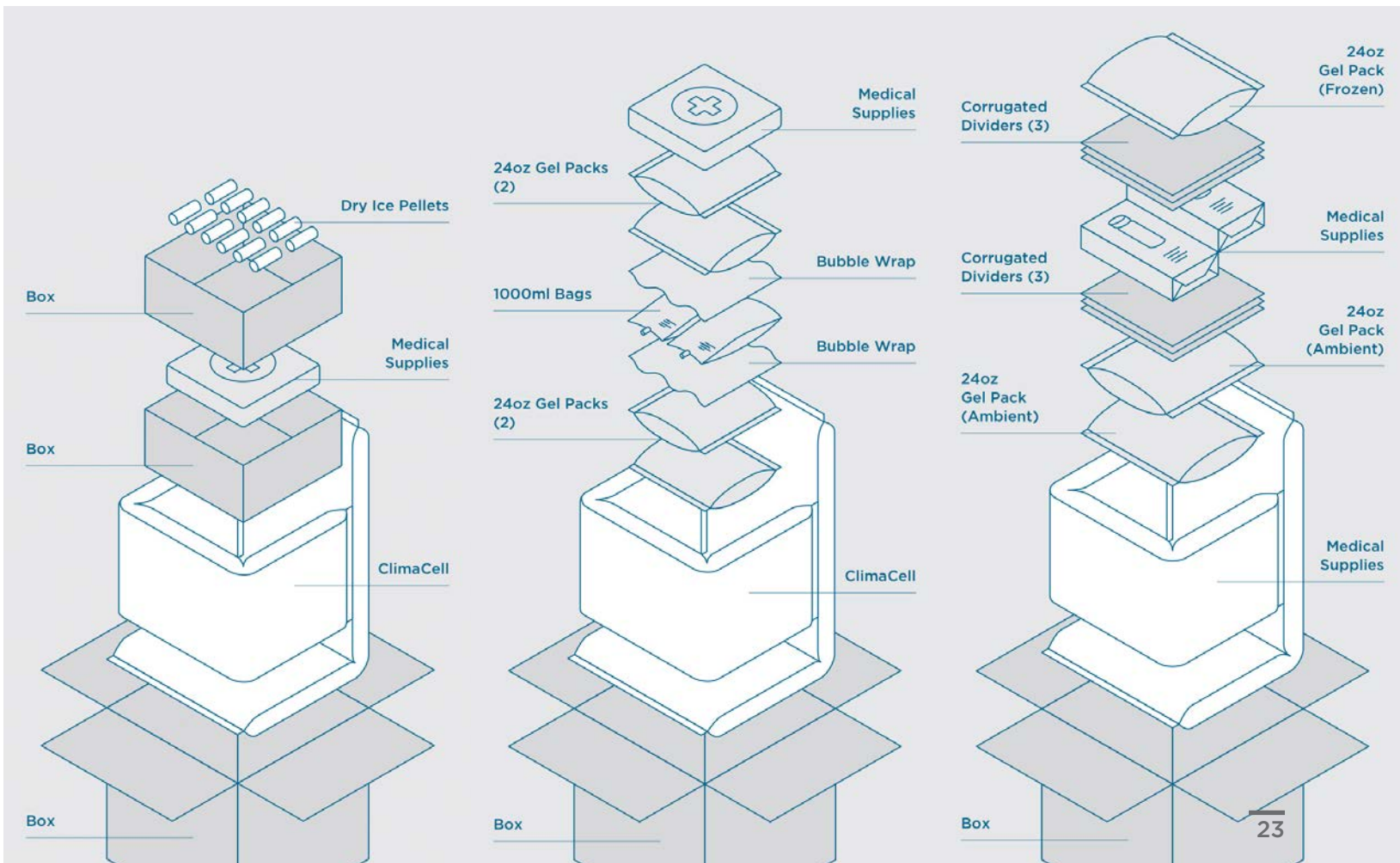

MESSAGING PERFORMANCE

Often, patients will ask to re-ship medications due to a perceived temperature excursion. Companies see this all the time with specialty drugs in the coldest months of winter and hottest months of summer. In the great majority of cases, these drugs are still potent, but the shipper must process a re-ship.

While our highest priority is real-world performance and patient safety, we believe it's imperative to communicate with patients that their medications are safe. That's why we work with our customers to design on-package messaging that inspires confidence.

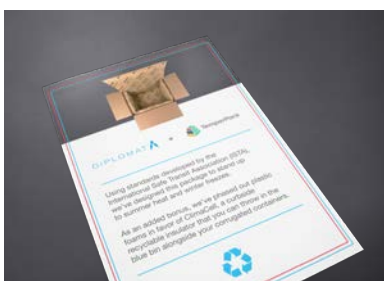

PACKAGING INSERTS

When a patient receives a shipment, that's a key moment of truth. We can work with you to ensure it's a positive one by developing an insert that explains the benefits of your new packaging. It's an easy and effective way to make a positive impression.



CUSTOM BRANDING

Packaging is valuable brand real estate. Our design team can add brand graphics and messaging to the ClimaCell™ cooler, as well as the exterior and interior of the shipping container. That's advertising that's guaranteed to reach your target.



COMPONENT MESSAGING

Shipping temperature-sensitive drugs requires a sophisticated pack-out consisting of several core components. We can work with our sourcing partners to add your branding to cooling elements and other parts of the complete package.



MESSAGING SUSTAINABILITY

Everyone wants to be environmentally friendly, but what does making a switch from Styrofoam® to ClimaCell really mean for your impact?

Many of our customers switch from plastic-foam-insulated shipping systems to ClimaCell, but they don't know how to quantify the environmental benefits. We offer complimentary consulting services to help you understand your positive impact, and to communicate it to your stakeholders.

**For every 100,000 12-inch³ Styrofoam® coolers replaced with ClimaCell, we eliminate the creation of enough CO₂E to...*



CUSTOM IMPACT GRAPHICS

Our in-house marketing team can help you quantify your impact and display it in custom designed infographics to share with your audiences.



Supply power to 1,214 homes for an entire year.



Plant 115,078 trees and letting them grow for ten years.



Change 264,468 incandescent light bulbs over to LEDs.



Take 1,478 cars off of the road for one full year.

**based on EPA Greenhouse Gas Equivalencies Calculator*



**WORKING WITH
TEMPERPACK**

WE STRIVE TO OFFER THE BEST CUSTOMER SERVICE, PERIOD.

We know that thermal shipping logistics can be a headache, so we try to remove as many of the pain points in the process for our clients. When you sign on to use TemperPack's insulated shipping solutions, you'll receive a dedicated operations liaison to guide you through your orders.

95% 

of our customers have continued working with TemperPack after receiving their first order.

20,000,000

Working for our clients, we've protected over 20 million shipments over the past 3 years.



JOINT PRODUCT DEVELOPMENT

Have a concept for a new thermal packaging system? We love partnering with our customers to bring new products to market. We have a team of engineers dedicated to solving our clients' thermal packaging problems.

Contact sales@temperpack.com to learn more about this process.

NEVER RUN LOW, GUARANTEED.

When you work with TemperPack, we develop an optimized shipping plan using our state-of-the-art ERP that's based on your usage needs. We guarantee you will always have ClimaCell coolers on hand for your shipments.

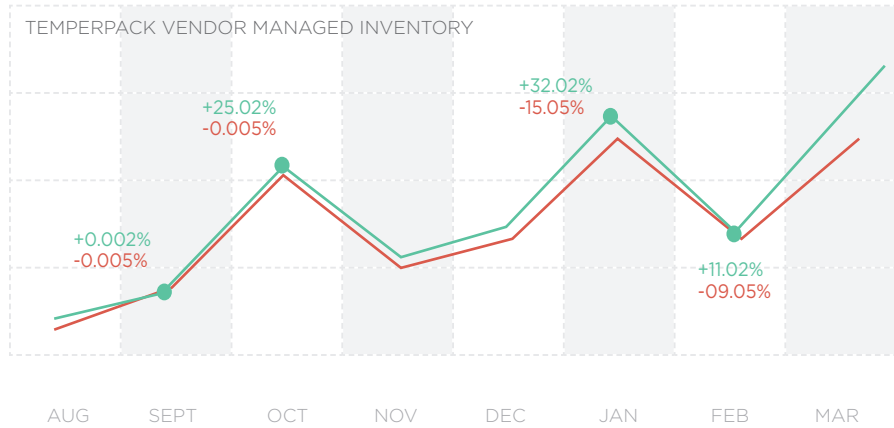

01 JUST-IN-TIME DELIVERIES

Need a high volume of coolers but don't have a lot of space? With our network of manufacturing sites, third-party logistics partners, and distributors, we can deliver as little as a pallet or as much as a truckload on short notice.

02 VENDOR-MANAGED INVENTORY

Tired of counting inventory every week? Give us access to your sales data, and we'll do the counting for you to ensure that you always have the right amount of thermal packaging in-house.

03 PRE-KITTED SYSTEMS

Don't have the labor setup to kit your ClimaCell shipping systems in-house? We can deliver pre-kitted systems anywhere in North America or Europe.

04 ENVIRONMENTAL IMPACT REPORTS

We offer complimentary consulting, including customer-friendly deliverables, to ensure that your marketing and PR teams have exactly what they need to be loud and proud about your switch to recyclable, low-emission packaging.

SERVING BOTH COASTS, AND EVERYWHERE IN BETWEEN

We manufacture ClimaCell across two facilities in Richmond, Virginia and Las Vegas, Nevada. That means, regardless of where your facilities are located, we can always have a shipment of ClimaCell coolers delivered to you within 1 day.

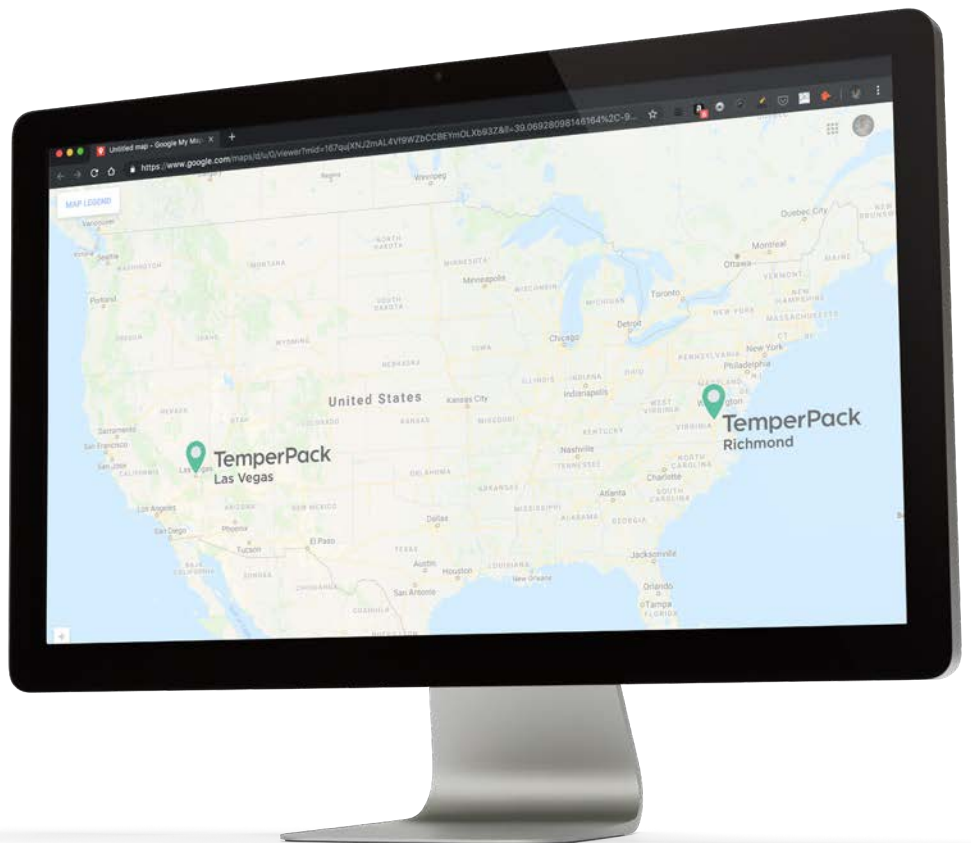



CLIMACELL TECHNICAL PACKET

TEMPERPACK TECHNOLOGIES,
INC.

CONTACT US



2660 Decatur St.
Richmond, VA



(888) 647-3630



www.temperpack.com
sales@temperpack.com